



INSTALLATION INSTRUCTIONS

DF/ED250PRO FIELD KIT (P/N 629087544)

Installation of Low CO2 Indicator Light

Parts List			
Item No.	Part Number	Description	Qty.
1	620313223	CO2 Pressure Switch	1
2	77060500	Tee 1/4MFL	1
3	40502	O-Clamp	2
4	77010400	1/4 Barb Stem	2
5	77045700	1/4 Flare Swivel Nut	2
6	178025100	1/4 Flare Washer	3
7	33666	Indicator Light 24V	1
8	620316401	CO2 Light Harness	1
9	620316402	CO2 Pressure Switch Harness	1
10	620313651	Jumper CO2 Pressure Switch	1
11	32870	Splice	2
12	50705	Cable Tie	8
13	620920638	Label Low CO2 Light	1
14	620919569	Installation Instructions	1

CAUTION: Disconnect electrical power to the dispenser before proceeding with the CO2 indicator light installation.

CAUTION: The Beverage System (water and CO2) must be depressurized and drained before proceeding with the installation.

1. Remove the upper front panel which is secured to the cabinet by "hooks" that fit into slots on the cabinet front flange. Lift up on the panel right and left sides to disengage the hooks from the slots and then rotate the panel downward and forward to remove from the cabinet. Disconnect the (3) electrical harnesses at the rear of the front panel.
2. Remove the lower front splash panel (2 screws).
3. Locate the CO2 supply line (1/4 beverage tubing) to the carbonator tank located on the right side of the unit above the coldplate (see Fig. 1). Cut this line in an area that will be accessible for future servicing and install the CO2 pressure switch with the fittings provided in the kit (see Fig. 3).
4. Refer to Fig. 2 for installing the CO2 indicator light on the upper front panel. Remove the lid and straw holder by loosening (3) screws at the "key-holes" and lifting up to clear the screw heads. Remove the lower front ice portion control enclosure (4 screws) and disconnect the electrical harnesses as needed for reworking the enclosure. Locate and drill a 1/2 in. diameter hole in the enclosure as shown in Fig. 2 for the indicator light. Insert the light from the front and "snap" into the mounting hole.
5. Refer to the wiring detail of Fig. 4 to complete the electrical hook-up of the indicator light to the pressure switch and the 24V beverage transformer power source.
6. Route the electrical wires to the CO2 pressure switch behind the beverage panel with the harnesses from the unit's electrical control box. Remove the (6) screws securing the beverage

age panel to the cabinet. The panel can now be pulled down to provide access for routing the pressure switch wires. Secure the wiring with the plastic cable ties provided in the kit to avoid “pinching” (cutting) the wire insulation when the panels are assembled to the cabinet.

7. Connect electrical power to the unit. Before opening the water and CO2 supply valves to the beverage system, verify that the CO2 indicator light is on. The indicator light should go off when the CO2 supply valve is opened.

8. Check for proper operation of the ice portion control system and the beverage system. Refer to the operation instructional label located on the upper front panel and the owners manual. The unit is now ready for operation.

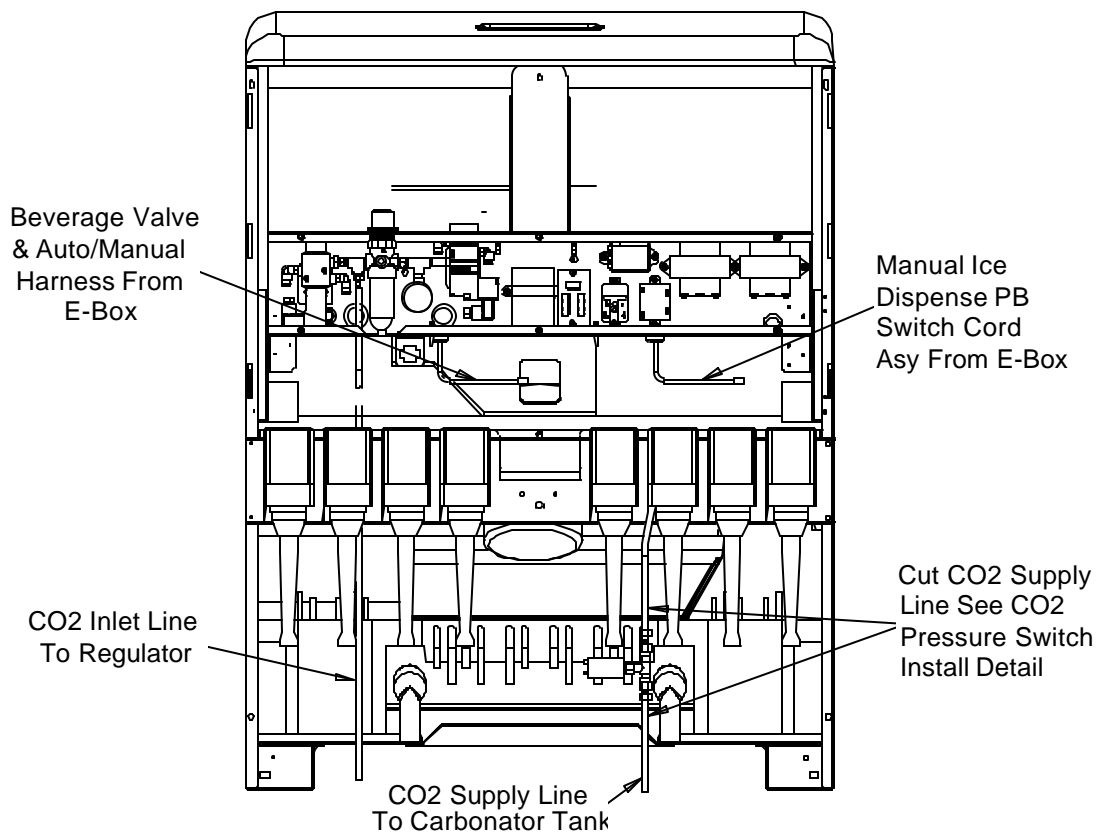

Figure 1.

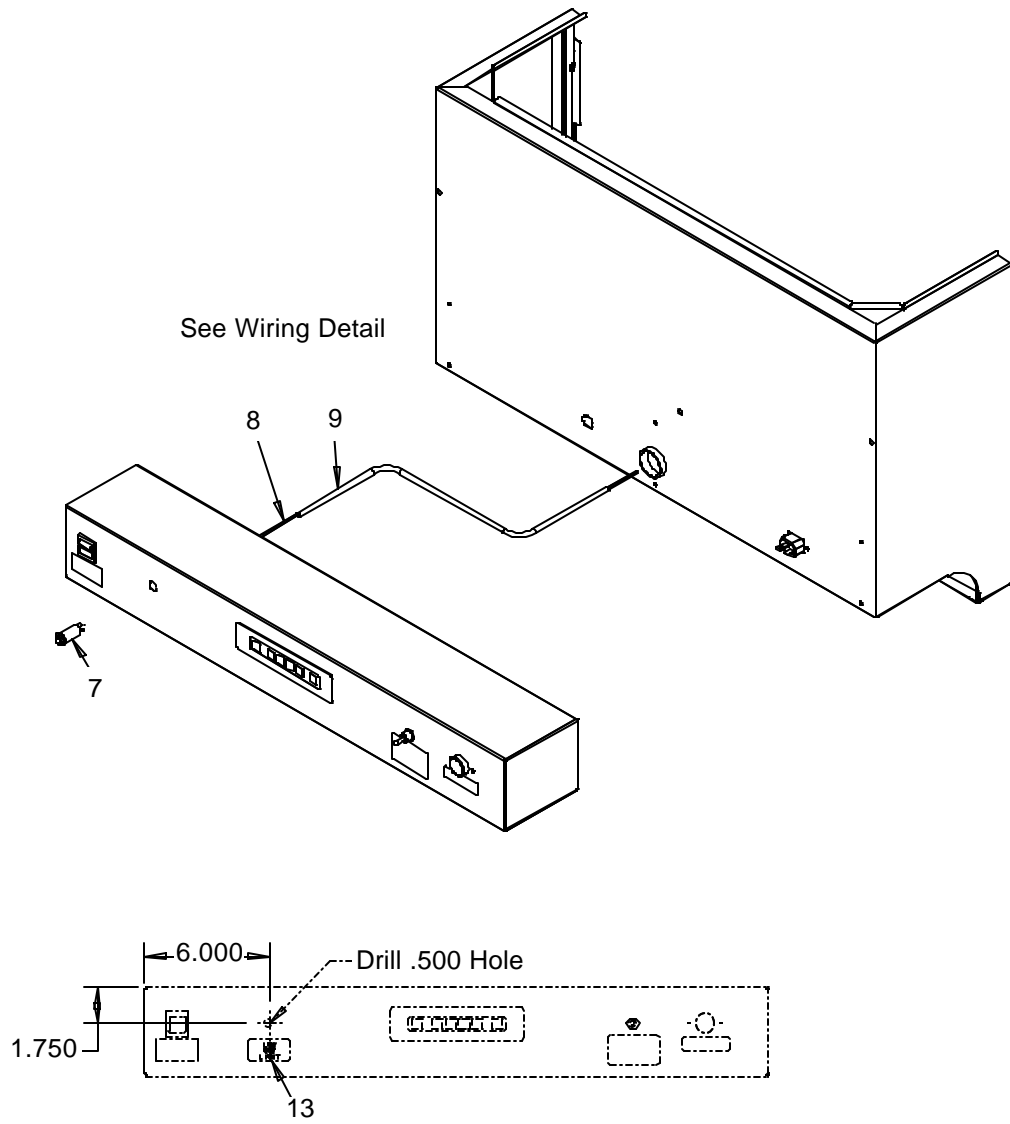

Figure 2.

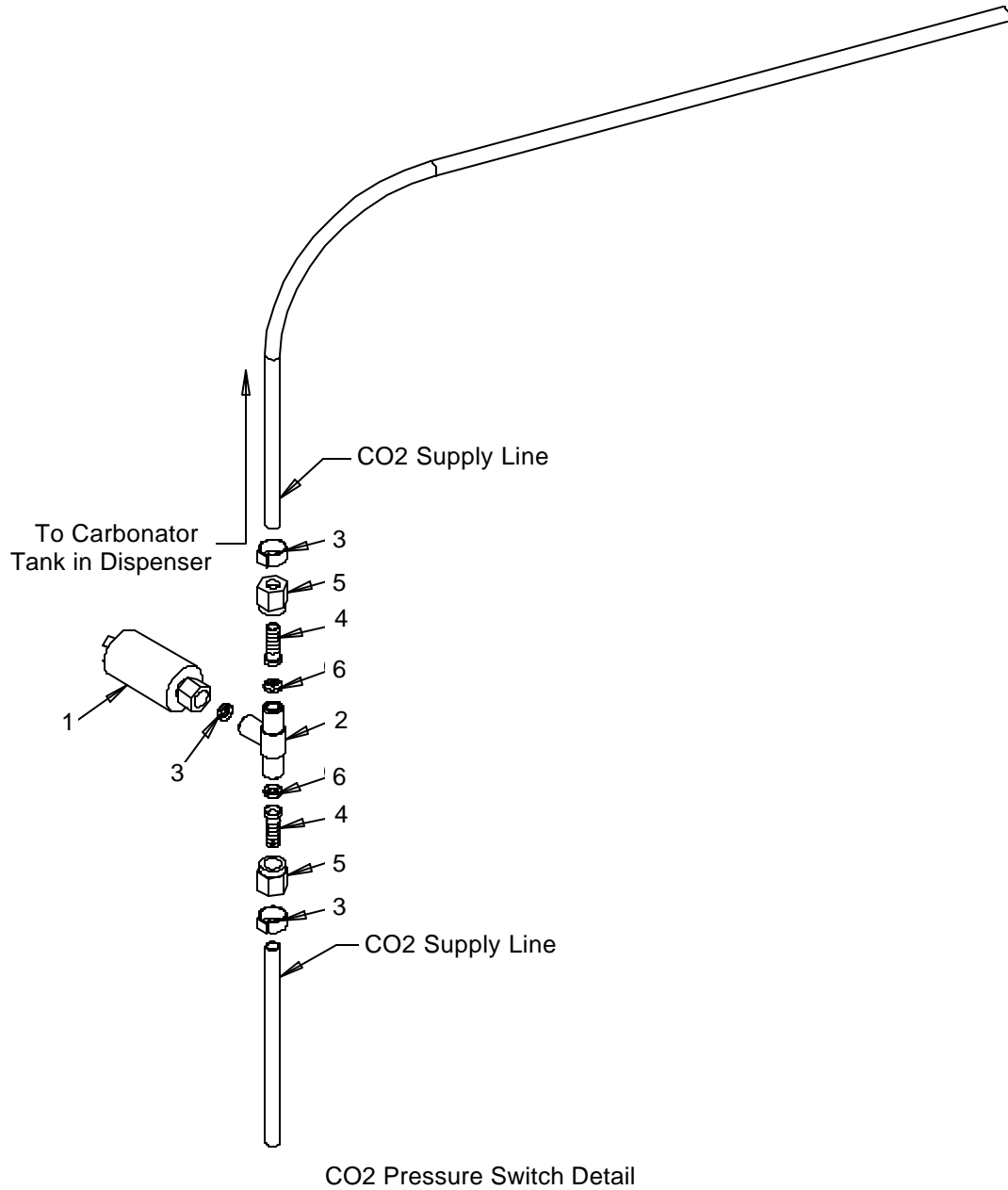
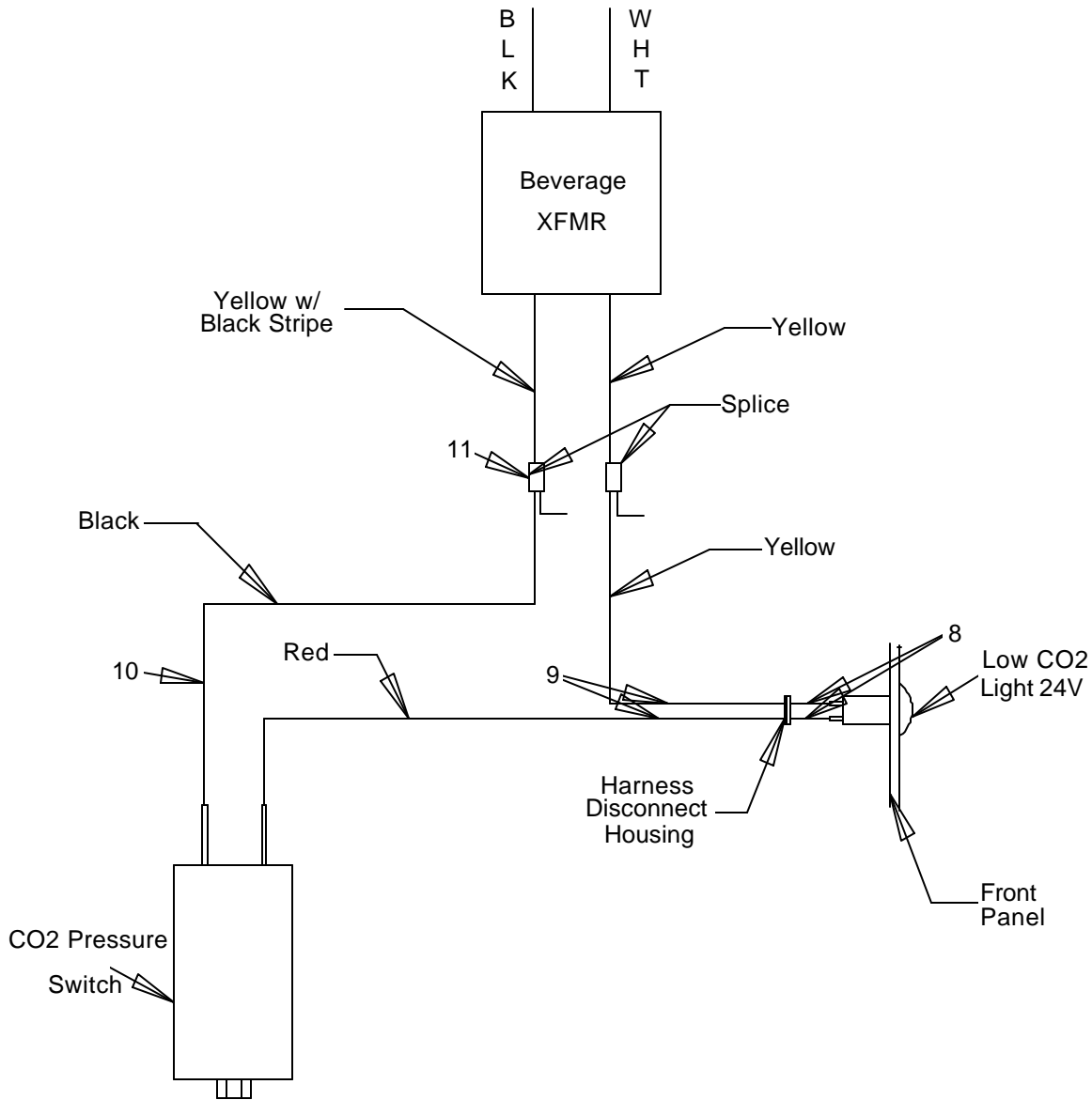

Figure 3.



Low CO2 Indicator Light Wiring Detail

Figure 4.